

ADA

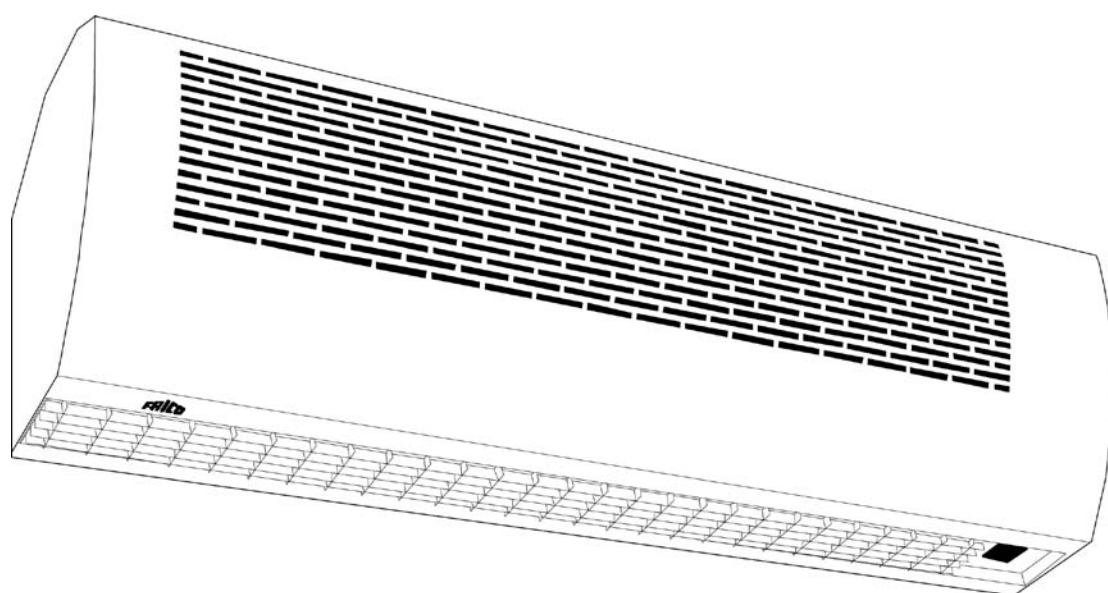

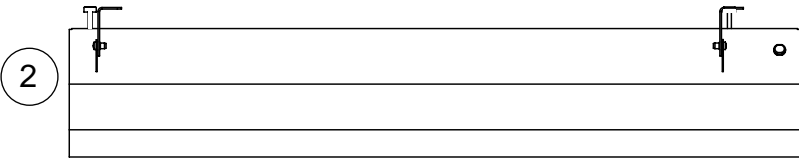

	L [mm]	L2 [mm]
090L	900	800
090H	900	747
120L	1200	1100
120H	1200	1047

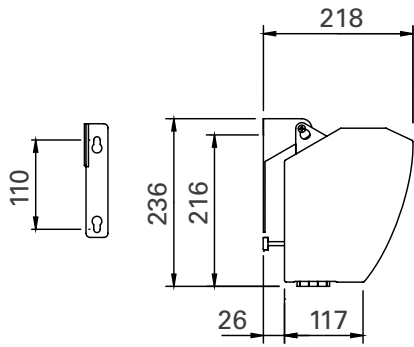
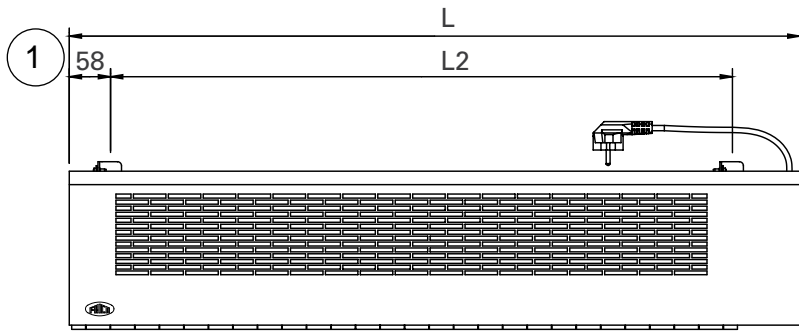
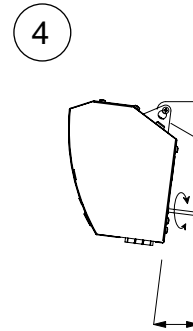
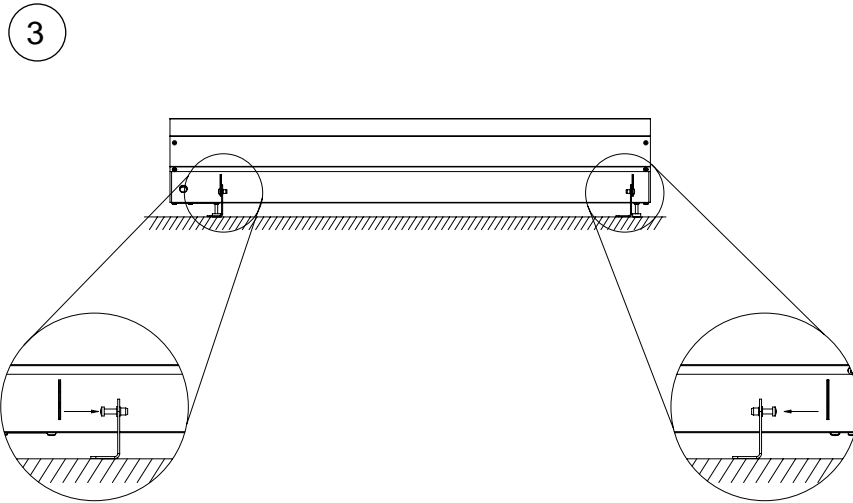

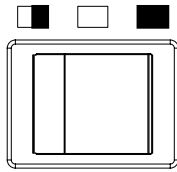

090L	625	820	m³/h
090H	800	1150	m³/h
120L	900	1350	m³/h
120H	1100	1400	m³/h

090L	8.7 kg	54 dB(A)
090H	9.5 kg	54 dB(A)
120L	10.8 kg	55 dB(A)
120H	11.7 kg	51 dB(A)

- SE: En skadad nätkabel får endast bytas av en behörig installatör
 GB: A damaged mains cable must only be changed by a competent electrician.
 NO: En skadet nettledning skal kun byttes av godkjent installatør.
 FR: Un câble d'alimentation défectueux ne doit être remplacé que par un électricien qualifié.
 RU: В случае повреждения питающего кабеля он должен быть заменен квалифицированным электриком.
 DE: Ein beschädigtes Netzkabel darf nur durch einen ausgebildeten Elektriker ausgetauscht werden.
 PL: Zniszczone przewody elektryczne mogą być wymienione tylko przez elektryka posiadającego odpowiednie uprawnienia elektryczne.
 FI: Vahingoittuneen verkkojohdon saa vaihtaa vain valtuutettu asentaja.
 ES: Un cable principal dañado sólo debe ser sustituido por un electricista cualificado.
 NL: Beschadigde bedrading mag uitsluitend door een bevoegde elektromonteur worden vervangen / gerepareerd.

230 / 220 V~
 50 / 60 Hz
 090H: 0,5 A, 120H: 0,55A (at highest)
 090L: 0,4 A, 0120L: 0,45 A (at highest)

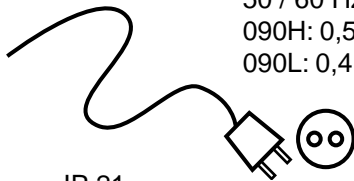

IP 21

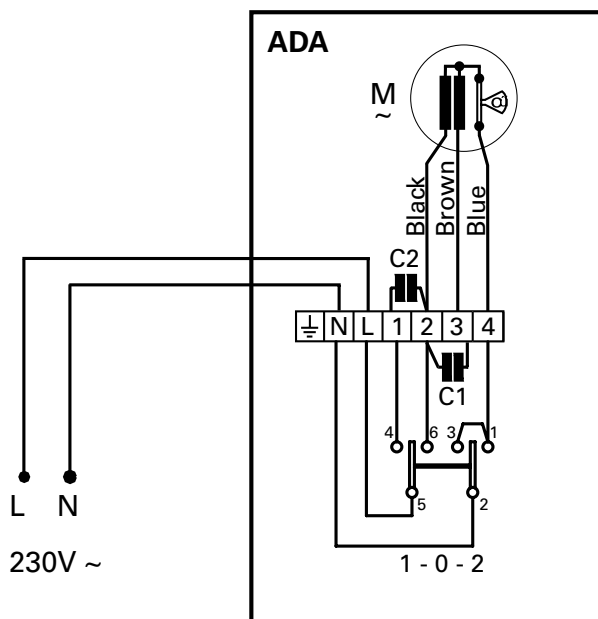

Main office

Frico AB
Box 102
SE-433 22 Partille
Sweden

Tel: +46 31 336 86 00
Fax: +46 31 26 28 25
mailbox@frico.se
www.frico.se

**For latest updated information and information
about your local contact: www.frico.se**